

CBT 800 POMPĂ CENTRIFUGALĂ CU 2 TURBINE

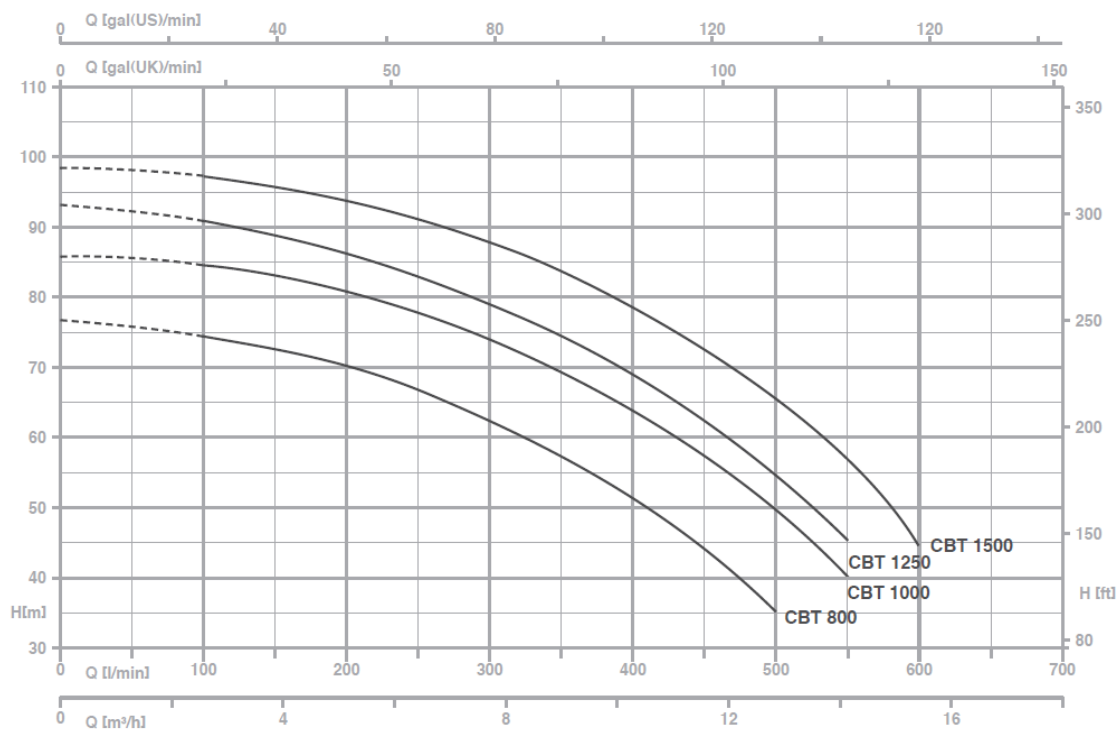



Putere absorbită P1:	8.5 kW
Putere P2:	5.5 kW
Alimentare:	400 V / 50 Hz
Înălțime de refulare max.:	77 m
Debit max.:	30000 l/h
Diametru de aspirație:	2"
Diametru de refulare:	1 1/4"

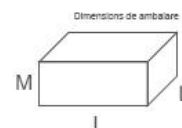
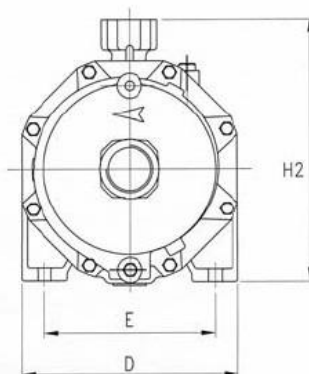
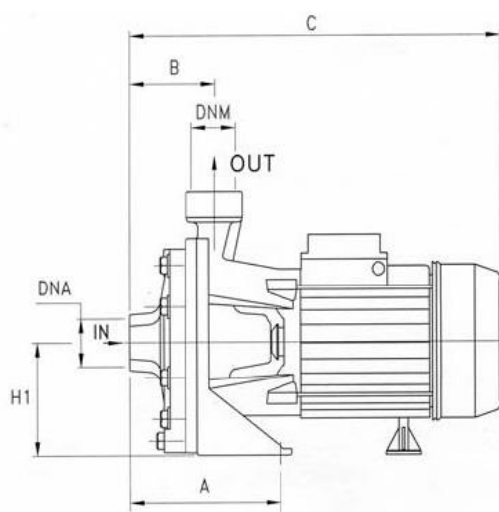

Debit Q (m ³ /h – l/min)					
0	6	12	18	24	30
0	100	200	300	400	500
Înălțime de refulare H (m)					
77	74.6	70.5	62.8	51.6	36

Temperatura maximă a apei:	50 °C
Carcasă pompă:	fontă
Suport motor:	fontă
Rotor pompă:	alamă
Etanșare mecanică:	ceramică – grafit
Arbore motor:	otel AISI 303
Clasă de izolație:	F
Clasă de protecție:	IP44



MODEL	DIMENSIUNI (mm)												
	A	B	C	D	E	H1	H2	DNA	DNM	I	L	M	
CB 100	122	72	328	180	140	98	228	1"G	1"G	350	195	265	15.3
CB 160	115	82	385	210	170	110	265	1"1/4 G	1"G	405	225	295	24.7
CB 210	115	82	385	210	170	110	265	1"1/4 G	1"G	405	2252	295	25.6
CB 310	115	82	385	210	170	110	265	1"1/4 G	1"G	405	2527	295	25.6
CB 400	145	95.5	463	266	212	135	305	1"1/2 G	1"1/4 G	500	5	3503	41
CBT 600	145	95.5	463	266	212	135	305	1"1/2 G	1"1/4 G	500	275	50	44.8
CBT 750	145	95.5	480	266	212	135	305	1"1/2 G	1"1/4 G	500	275	350	50.5
CBT 800	190	120	605	275	210	150	330	2"G	1"1/4 G	640	310	370	70.5